

Routing Techniques for DOLLS HOUSE MOULDINGS

trend
routing technology



A 32 page guide to producing dolls house and miniature mouldings

BOOKLET

3

BOOK/DH1

IN A SERIES

1 INTRODUCTION

One of the most pleasurable aspects to making your own dolls house is the fitting of the mouldings in each room. They must be machined to the correct proportions and from the right period to be accurate. Although 1/12th scale pre-machined mouldings can be purchased from Dolls House shops and hobby shops, there are many advantages in actually producing them yourself.

Often it is difficult when purchasing mouldings to obtain uniformity as they can differ from batch to batch. The shapes of the moulds can be different and the overall dimensions of the purchased mouldings can be out of proportion or even oversize. The price of these pre-machined mouldings can also prove to be quite expensive, especially when buying skirting and cornice mouldings as long lengths are usually required.

All the proportions of 1/12th scale mouldings must be an accurate scaled down version of those found in full size building joinery. The ideal means of obtaining the correct size moulding is, therefore to make your own. There is of course also a sense of achievement from machining the moulds yourself from start to finish and, added to this, your dolls house project can be completed to your own unique specification.



ABOUT THE 12 PIECE SET



The dolls house cutters in the set are all tungsten carbide tipped. Tungsten carbide is a hard, wear-resistant metal that gives long cutting edge life and will give a clean cut on the timbers used in scale moulding manufacture.

Nine of the cutters in the set are specifically designed to carry out the making of mouldings. The three straight cutters can be used for rebating, grooving and slotting these mouldings.

trend routing technology

They can also be used for the construction of other parts of the dolls house such as the wall and roofing components.

The moulding cutters allow the dolls house maker and miniaturist to run whatever length of moulding is required. If a small length of mould is kept on file, the router can be set against the sample, to enable further lengths to be machined to replicate the original. These later lengths of mould will be the same as the earlier lengths, so ensuring uniformity.

Using standard hand routers one can machine virtually all types of scale moulds, including stair handrails, skirting, cornice, coves, architraves, capping, and stair tread nosings. They can be used for different styles, including Victorian and Georgian periods. By using certain parts of the shapes in conjunction with others, unique moulds can be achieved. Numerous variations of

moulding, even more than those shown in this booklet, can be produced. The timber used for the mouldings is in imperial sizes. The chart below can be used to convert them to metric equivalents.

Imperial	Metric
1/16"	1.6mm
5/64"	2.0mm
3/32"	2.4mm
7/64"	2.8mm
1/8"	3.2mm
9/64"	3.6mm
5/32"	4.0mm
11/64"	4.4mm
3/16"	4.8mm
13/64"	5.2mm
7/32"	5.5mm
15/64"	6.0mm
1/4"	6.35mm
5/16"	8.0mm
3/8"	9.5mm
7/16"	11.0mm
1/2"	12.7mm
9/16"	14.3mm
5/8"	15.9mm
11/16"	17.5mm
3/4"	19.1mm

ADDITIONAL REQUIREMENTS

What else do you need?

The router

The dolls house cutters have either 1/4" (6.35mm) diameter shanks or 8mm shank diameters and can be fitted to light duty routers, such as the Bosch POF500A and Black & Decker BD780. A variable speed facility on the router is not necessary for producing dolls house mouldings. The small diameters of the cutters allow spindle speeds up to 27,000 RPM to be used.



More professional routers such as the Trend T5 can also be used. These have the benefit of more power, and the availability of a fine height adjuster. The most important factor is that of power. Your router must have a power rating of at least 500 watts to achieve the best results. Small handheld types of grinders or drilling units such as the Dremel® or Minicraft® are not suitable for use with this set.



3

The table

Because of the extreme accuracy that must be achieved and the small nature of the timber being machined, the router must be used fitted inverted into a router table. The dolls house router cutters are unguided (i.e. they are not fitted with a guide bearing) and therefore the material must be guided to engage the cutter by a straight line guide or back fence. Other additional guiding mechanisms which will be described later, may also be used to machine the timber accurately and safely.



trend routing technology

2 THE ROUTER TABLE

To actually cut the moulds the router must be fitted inverted in a router table. Proprietary tables are readily available, but a home-made table can be constructed to suit your own requirements.

CRAFTSMAN ROUTER TABLE

The **Trend Craftsman Router Table** is a general purpose router table which can be fitted with the necessary home-made adaptations for machining dolls house mouldings.

It should be fitted with a false table top so that the aperture through which the cutter projects, will be as small as possible. By fitting a false top, guards and other

devices can be easily screwed to it. The false top can be constructed from 6 or 9mm MDF (Medium Density Fibreboard) or plywood, and should be slightly larger than the alloy table itself. The false top should be drilled out to match the fixing holes in the Craftsman table surface. The false top can be screwed to or held by battens onto the alloy table top of the table. The back fence can also be used if a false cheek is fitted to it. This cheek will need a small aperture cut into it. The false cheek can again be constructed from MDF and can be screwed or clamped to the existing back fence.

A **Home-made router table** can be made very simply from MDF or other flat stable material.

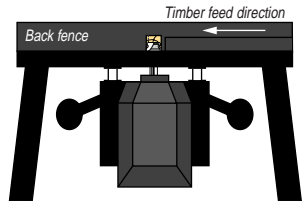

Side view

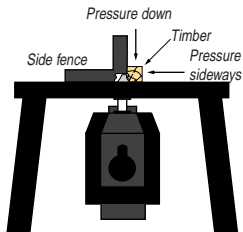

End view

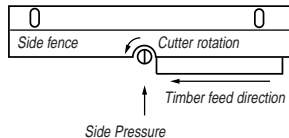

Plan view

ROUTER TABLE CONSTRUCTION

A home-made dolls house router table is simple to make, even with only limited woodworking skills. It is made of easily available MDF or from plywood and uses fittings from the Trend range of routing jig accessories. (Please see the current Trend Routing Catalogue).

The low fence fitted to the table is again cut from MDF and slotted to allow adjustment of the cutting width. It is fitted with a dust extraction hood (Trend Part No. RR72). This also acts as a back guard to prevent accidental contact with the cutter. We strongly recommended that this or a similar guard is fitted.

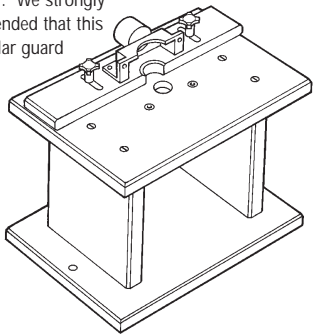

INSTRUCTIONS

1. Cut the 4 leg pieces to size from 15mm thick MDF and glue each pair together with PVA adhesive. When dry, plane both to the same size and square, and chamfer the vertical edges.
2. Cut the base from 15mm MDF and plane the edges square.
3. Cut the Table top from 12mm MDF and square the edges.
4. Mark the centre point of the top and neatly drill a 25mm diameter hole.
5. Using a paper template (or if possible use the removable facing from the base of the router), mark the position of any suitable fixing holes in the router baseplate, centred around the 25mm hole.

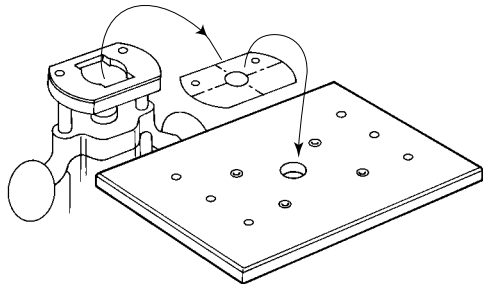

6. Drill and counterbore holes to take suitable fixing bolts.
7. Drill and counter sink the fixing holes to take the No.10 x 1 1/4" chipboard screws.
8. Cut the under rail from 15mm MDF.
9. Assemble the table by screwing and gluing each joint and checking that all is square before leaving to dry.
10. Cut the table fence from 12mm MDF and trim the edges square.

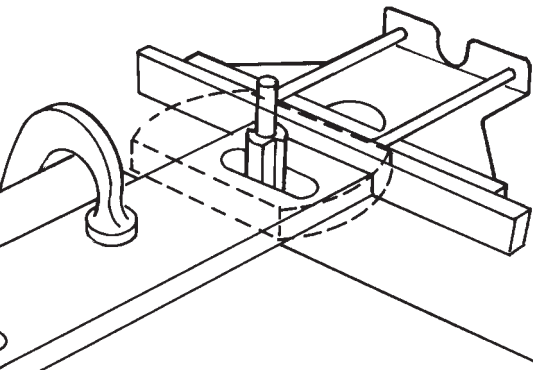

11. Cut the two slots using a 1/4" diameter straight cutter and setting the router's side-fence to run against each end of the MDF in turn. A 1/4" diameter straight cutter can be obtained from the Trend Routing Catalogue or is available in the Set SS3. Please see inside the back cover of this booklet.
12. Position the fence on the table and mark the centre of the lobe knob holes.

13. Drill the appropriate diameter holes through the top and insert the pronged tee-nuts.
14. Mark and cut the semi-circular cutter recess along the fence edge to match with the hole through the top.
15. Screw the guard/dust extraction port to the top face of the fence.

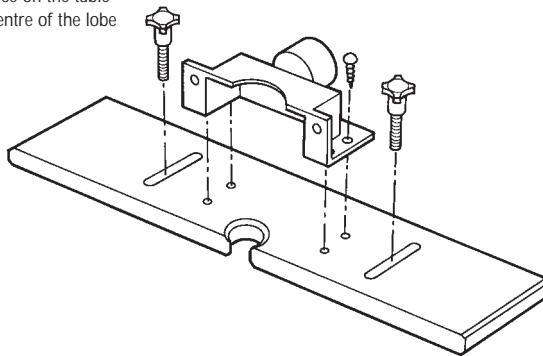

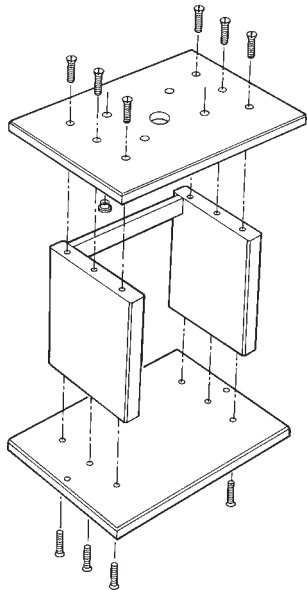

Materials Cutting List (all in mm)

<u>Description</u>	<u>Size</u>	<u>Qty</u>
Base board	300 x 475 x 15	1
Legs	220 X 275 x 15	4
Top	300 x 500 x 12	1
Fence.....	100 x 500 x 12	1
Under rail	38 x 335 x 15	1
Guard/dust spout	(Trend no RR72)	1
Pronged Tee-nuts	M6	2
Lobe Knobs	M6	2
Washers	6mm	2
Chipboard screws.....	No.10 x 1 1/4"	12

Special Notes

Table size

The table surface area can be made to any suitable size, but should be large enough to allow ease of operation.

Central aperture

The aperture through which the cutter will protrude should be as small as possible. The hole should only be about 3mm larger than the tool diameter. In the case of the home-made table, the hole is made to suit the largest dolls house cutter in the set, and should therefore be about 25mm in diameter. A false table fitted to the top of the machine table with a smaller diameter hole can always be fitted when using the smaller diameter cutters.

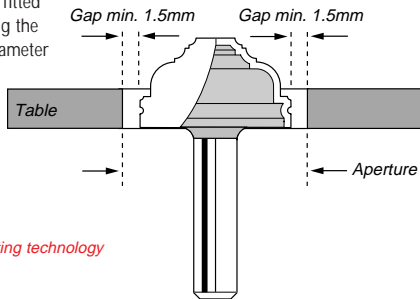
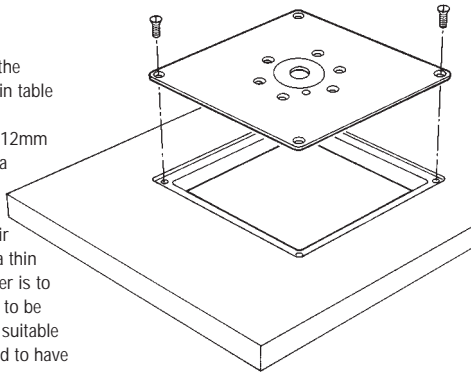

Table Thickness

The recommended thickness of the machine table is 12mm. This thin table top allows maximum projection of the tool above the table. The 12mm table top can be reinforced with a stretcher underneath to prevent sag. As only light routers are needed for dolls house work their weight is not too great to allow a thin top to be used. If a heavier router is to be used, then the table will need to be thicker, i.e. 18mm MDF or other suitable material. The table will then need to have a thinner plate recessed into it from which the machine can be secured.



This thinner plate can be made from metal.

The metal insert plate that fits into the Craftsman Router Table is available as an accessory and can be used for this purpose. The plate is available with different pre-drilled countersunk holes for the most popular makes of router.

Please refer to the latest Trend Routing Catalogue.

Fitting the router

Two counter-bored holes are used for this purpose. These holes are oversized, so that the pan head machine screws that thread into the base of the router, can be moved in the counter-bored holes to allow exact centring. For instance, the Trend T5 has two M6 threaded holes in its base (which are used to secure to jigs etc.) and therefore the counter-bored hole should be 12.7mm (1/2") in diameter and the through hole should be 6.35mm (1/4") to 7mm in diameter.

*Counter-bored holes
allow exact alignment*

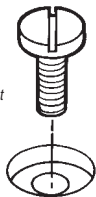

Back fence

The back fence must be planed square and true. The fence has two slots routed into it, enabling it to be secured to the table top. The table top has two pronged tee nuts fitted to its underside. These pronged tee nuts have an internal thread size of M6, which is the same as the threads on most knobs on routers for fixing of the side fence and guide rails. These now redundant knobs can be used to secure the back fence to the table. The slots on the back fence have to be rebated to allow the knobs to tighten properly in the tee-nuts.

Back fence aperture

This allows the cutter to project through the back fence. This aperture must not be too wide, (here suggested of equal diameter to the hole in the table). This is to allow all parts of the tooling to be used, enabling different moulds to be machined.

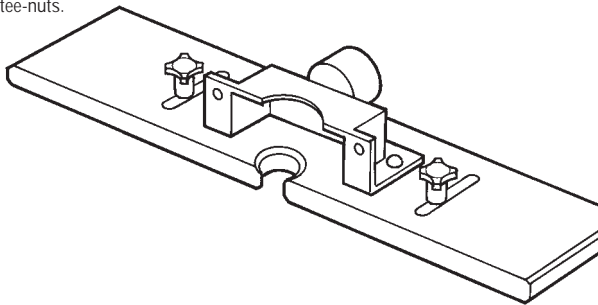

With the machined component having a maximum height of 5/8" it is therefore necessary to have a back fence of 12mm MDF. The fence could be fitted on the back edge with a higher batten for thicker work, such as higher skirtings etc. This high batten will also need an aperture machined in it to accept the cutter. This would make the fence reversible. Depending on which size of component is being machined, the higher fence can be used for thick stock and the thin fence for narrow stock.

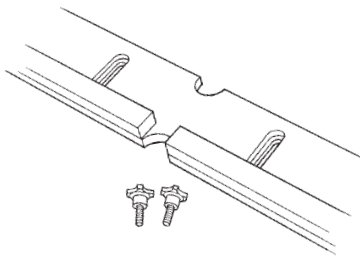

Dust Extraction

The back fence can be fitted with a dust spout so that a dust extractor can be fitted. This shroud can be taken from a spare proprietary back fence or purchased separately. The shroud not only allows extraction of the wood waste but also protects the back of the cutter. Two holes in the face of the shroud also allow a user-made chip deflector to be fitted. It is always advisable that a dust extractor is used when routing to remove the wood chips and dust at source. A hose can be attached at one end to the dust extractor and the other end can be fitted into a dust spout fitted to the back-fence of the table.

Pressure Guards

The back fence and machine table give the component being machined a good supporting area, but top and side pressures are also necessary to stop the material lifting or being pushed away from the cutter. These pressure guards will also make it safer to rout the material, as the operator's hands are kept well away from the rotating tool. Various pressure fences can be used, these include spring loaded blocks, finger pressures (shown above) and concertina type pressure guards. When possible it is advisable to use thin material for the pressure guards for dolls house mouldings such as 12mm MDF. A rebate may need to be cut on the edge that would abut the component, to allow access with a push stick.

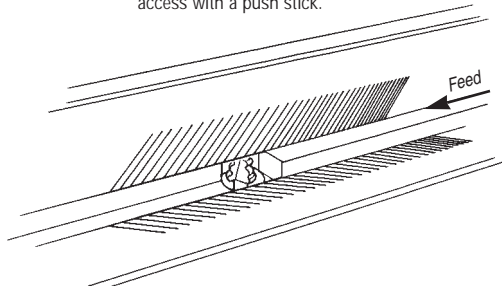

Push Stick & Push Block

A push stick and push block are also advisable to help guide the material being moulded. The push stick should be at least 350mm long and can have a 'bird's-mouth' shape cut-out on one end. This end should also be cut with a taper to make the 'bird's mouth' narrower to allow greater access between the pressure guards. The push stick is used on very small components to push the component past the cutter and therefore to keep the operators hands well away from the cutter.

A push block is a device which also can be used to hold small components to ensure stability and safety when routing.

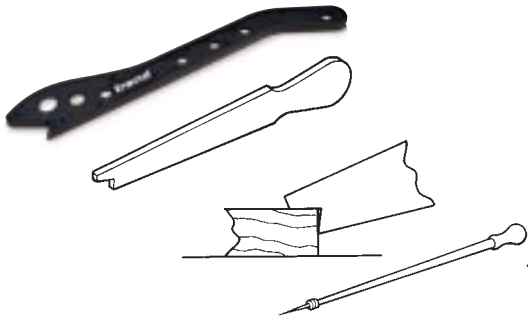

A cross cutting jig is used to rout across the grain. The jig has a batten on it, that is square to one edge, and this acts as a support when cutting across the ends of narrow components.

No-Volt Release Switch

The router table should be fitted with a No-Volt Release Switch (NVRS) this can be secured to the leg or workboard to provide easy access to the on/off buttons. Should the power supply to the router be turned off at source, the router will not re-start until the green button is pressed. This NVRS is available as an accessory, Trend ref. E35146 (230V).

Fine Height Adjuster

The routers used should ideally have a fine height adjuster fitted (for Elu MOF96, Trend ref. E40906) which would fit in place of the depth stop flag on the router. This fine adjuster allows the router cutter to be set at the correct height for the mould. By turning the fine height adjuster one way or the other the cutter will be raised or lowered. A fine height adjuster is essential for any router that is used inverted in a table.

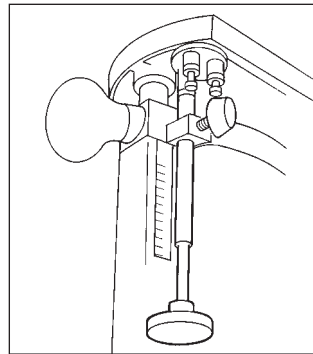

trend routing technology

3 ROUTING TECHNIQUES

Choice of Timbers

The choice of timbers should be ideally a hardwood which is straight, close grained and does not tear when machined. Suitable timbers include Lime, Brazilian Mahogany, Obeche, Jellutong and Ramin. Beech can also be used but when machined to small sizes the surface can give a pitted effect.

Preparing the timber

The easiest way to mould the timber is to first plane it with square sides by hand or machine. The timber should be machined in thickness to suit the particular type of moulding required, i.e. 5/8" or 3/4" for the height of skirting, 3/16" for architrave height and so on. The timber should be kept as wide as possible to give good support when machining.

trend routing technology

Moulding the timber

The mould can then be routed on one edge only, usually the full mould is created in one pass, as it is not normally necessary to take many shallow passes due to the very small nature of the cut. If the moulded edge has feathered slightly (this is dependent on the timber used) the mould can be passed through the cutter again. The correct sequence is needed to ensure a good mould is obtained. There are four different methods for machining mouldings. These are as follows:

Method 1

The moulding is first machined onto the edge of a wide piece of timber. The moulded edge is then parted from the timber on a small diameter saw bench. The sawn edge on the moulding should be quite clean providing a fine tooth parting blade is used. The edge can then be planed true and the operation repeated until the timber is too narrow to hold properly. This method ensures that the timber is supported properly on all cuts and that it is less likely to twist whilst routing.

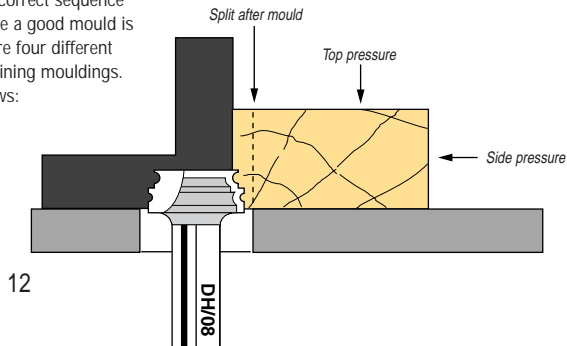

Method 2

The timber is first parted to the correct thickness on a saw bench. Each strip is then moulded.

The timber must be planed to the correct height for the mould required before parting. The thin stock must then be cleaned up. Several lengths of stock can be parted in one session. Due to the very thin nature of the material the side pressure fence must be set very accurately when moulding so as to

prevent material tilt. Flexing and fracturing of the strip could also occur, so ensure a slow constant feed rate is maintained.

Method 3

As method 2, but square or rectangular prepared sectioned timber is purchased already to size. These are then moulded.

Method 4

An alternative method to 2 and 3 is to fix the thin sections of timber to a larger piece of material, such as a straight section of MDF. This can be achieved using double-sided tape, which will ensure the moulded section can be removed afterwards. This method is especially useful for very awkward strips, which would otherwise twist or vibrate when being routed.

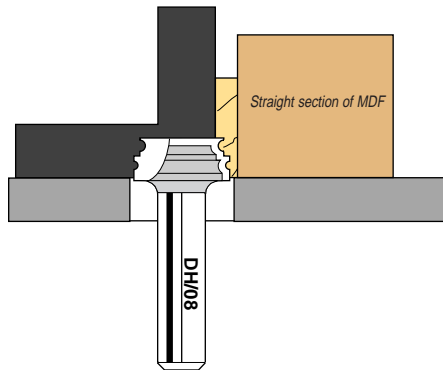
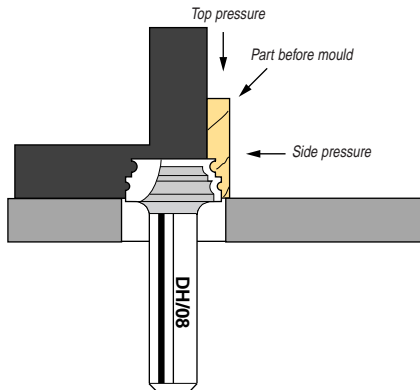

Routing procedure

1. The height of the cutter is set so that the relevant parts of the tool that create the mould required are correct.
2. Set the back-fence to ensure the correct depth of mould into the timber will result.
3. Adjust the top pressure guard until it touches the top of the blank material to be cut.
4. Clamp in position. Repeat for the side pressure guard.
5. Switch the router on and test the mould on a waste piece of timber.
6. When routing use the push stick to help move the blank material towards the cutter. Keep the feed rate constant.
7. Mould the timber along its whole length. When the moulding is complete switch off the router.

Square sectioned moulds

Some mouldings such as handrails must be cut with the timber having been machined to its finished size prior to its moulding i.e. 1/4" square for a handrail. A moulding of this size is more difficult to machine due to its very small nature, which can tend to twist, and vibrate. By using side pressure guards and a saddle (a material support made from an offcut) on the outfeed side of the machine table, these difficulties can be overcome.

Setting up for skirting boards

Skirting boards are the easiest moulds to rout. The simplest method is to cut the mould on a wider piece of timber and then part it afterwards. The timber is prepared to the correct thickness such as 3/4" high for tall skirting or 5/8" for smaller skirting. Pre-parting the timber and cutting the mould on the thin strip can also be done in the same way but extra time and care will be needed to

ensure that the thin strip does not flex or tilt whilst the mould is cut.

Architrave

The simplest method is to cut the mould on a wider piece of timber and then part it afterwards. The timber is prepared to the correct thickness for architrave such as 1/4".

Handrails

For handrails the timber is prepared to the correct dimension such as 5/16" x 1/4". Machine the first edge, and then turn the material, so that the mould can be repeated on the opposite side. Once the edge moulds are complete the groove on the underside of the handrail to accept the stair spindles (or balusters) can be routed.

Fit the 1/8" diameter two flute cutter Ref. DH/07 into the table. Set the height of the tool to the depth of cut required. Reset the back fence so that the groove is central to the hand rail. Set the top and side pressures as normal, rout the groove in two passes, to remove any wood chips caught in the groove and to give a cleaner cut.

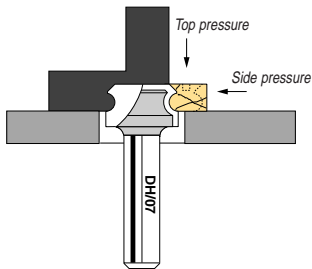

Furniture moulds

For panels, table tops and shelves of cabinets etc, the timber is prepared to the correct thickness and dimension. Set the cutter height and back fence to the correct position. The panels are routed across the grain (short grain) first, then the mould is routed along the grain. If a deeper mould is required reposition the cutter height or fence. Alternatively a different part of the cutter or a different cutter can be used to build up the mould. When cutting across the grain due to the very small nature of the components, it may be necessary to hold the component in a jig to ensure it remains at 90° to the cutter. This jig can be made of MDF and have a batten secured at 90° to its edge adjacent to the back fence, to act as a guide to keep the component in the correct position.

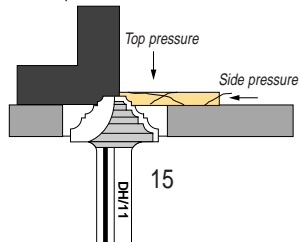

Cornice moulds

The timber is prepared to the correct dimensions such as 3/8" thick. The operation is similar to that for cutting skirting boards. A mould should be cut on a wide piece first and then parted afterwards. Due to the general size of cornice moulds it may be necessary to take two passes by varying the back-fence positions to achieve the mould. For softer timbers, the mould can be machined in one pass. If it is necessary to cut the cornice on a square piece of timber the same method as cutting a handrail can be used. However as a large portion of the material is removed, a support or saddle may be required on the outfeed side of the table to prevent the material from tilting.

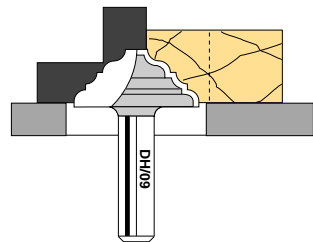

Door and fireplace surrounds

The simplest method for door and fireplace surrounds is to cut the mould on a wider piece of timber and then part it afterwards. The timber is prepared to the correct thickness suitable for the surround.

Some door surrounds have a series of parallel grooves running along the full length. These can be achieved by setting the height for one groove, machine along its length. Turn the material over and machine the second groove. The last groove in the middle of the surround can be routed by resetting the height of the cutter until it is in the centre of the timber section.

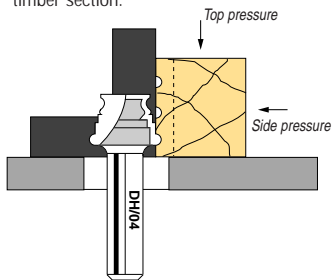

Picture frames and mirror

The simplest method for most shapes, is to cut the mould on a wider piece of timber and then part it afterwards. The timber is prepared to the correct thickness for framing and routed using the same methods as cutting architrave. To rebate the back of the frame, fit the two flute straight cutter ref. DH/03 into the table and set the height to give the correct height of rebate. Position the fence so that the correct depth of rebate is obtained. The timber will become very narrow and quite weak, so fit the top and side pressure clamps to securely hold the material being routed. The mould is then parted from the core material on a saw bench.

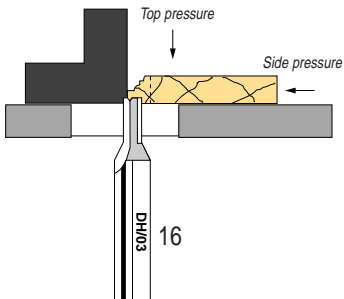

Grooving and rebating

Rebates and grooves can be routed using the straight fluted cutters. The smallest diameter cutters must be used with great care as they can be broken easily if too deep a cut in one pass is made. For rebates, it is advisable to use the larger diameter two flute cutter ref. DH/03. Even larger diameter straight cutters are available. These can be purchased separately, such as Trend refs. C006x1/4TC which has a 6.3mm (1/4") diameter or C013x1/4TC (9.5mm or 3/8" diameter). For both grooves and rebates the cutter is fitted into the table and the height of the tool is set. Once the height is set, position the fence so that the correct depth of rebate is obtained.

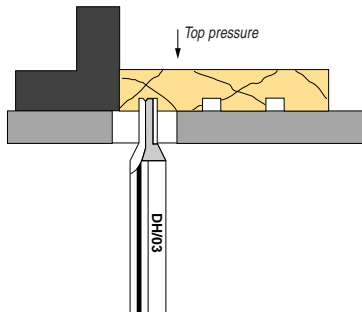

Finishing

The moulds can be cleaned up with fine wire wool. Rough sawn edges can be cleaned up with fine grades of abrasive paper glued to a flat board, or by using a hand plane.

The mouldings can be stained, painted, oiled or left uncoated.

Guide bushes and templates

With the router used portably, a guide bush can be fitted and used in conjunction with a template. It enables the router to be guided around the edge of a pre-cut template or along a slot of similar width as the guide bush diameter.

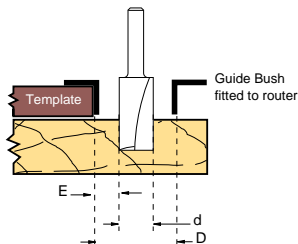

The guide bush itself, is fitted flush into the base of the router, and has a short flange concentric to the cutter. This flange is run against the edge of the template or guide. When routing, follow the normal feed direction (i.e. against the rotation of the cutter), depending on whether it is an internal or external template. Keep the flange tight against the template and do not lift the router as the cutter will damage the template edge. The cutter will always leave rounded corners. These can be trimmed square with a sharp chisel.

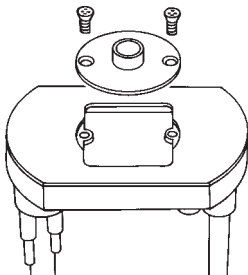

The template can be made from 6mm plywood or MDF. The use of thin material allows ease of shaping and finishing.

When drawing out the template shape, remember that the difference between the cutter and outside guide bush diameter needs to be allowed for. This margin (E) is calculated by deducting the cutter diameter (d) from the guide bush diameter (D) and dividing the remainder by two. For external templates deduct this amount from each edge of the template or guide, or for internal templates add this amount to each edge.

Walls and window apertures

Templates can be made that allow the router to rout out the window apertures and doorways, as well as cutting the outer edges of walls and roof sections. The straight two flute cutter Ref. DH/03 used in conjunction with a guide bush will enable the shape of a template to be followed on thin material, no more than 6.35 (1/4") thick. Several passes must be made. For normal thickness walls (i.e. 3/8" ply or MDF) a straight cutter must be purchased separately, with a larger diameter and longer cut length, e.g. C013x1/4TC. The machined edges will only require minimal cleaning up

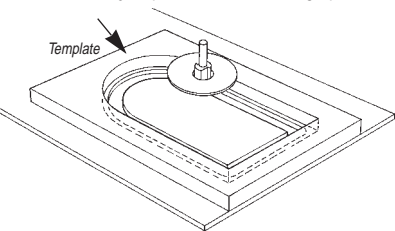

trend routing technology

with abrasive paper. Choose a guide bush diameter that will leave at least 2mm clearance between the cutter and inside edge of the guide bush ring, to allow waste to clear easily. Alternatively a bearing guided trimmer cutter can be purchased, this will enable the template to be made the same size as the finished product. This cutter is available separately in the Trend Craft Range or is included in the 12 piece Starter Set ref. SET/SS3. See inside back cover for details.

Recessing hinges for dolls house fronts

A simple template cut from thin plywood can be used for recessing hinges. Cut

the template to size allowing for the guide bush margin. Pin a clamping block to the template edge or simply clamp the template in position over the work. Square the routed corners of the recess.

Joining walls and roofs

A guide bush can also be used for cutting grooves to form joints between walls. This is carried out using a 'Tee square' with a slot, the same diameter as the outside guide bush diameter, cut along the blade of the square. Edge joints are best formed by cutting a rebate, either using a self-guiding rebate cutter, or a straight cutter held in a table-mounted router.

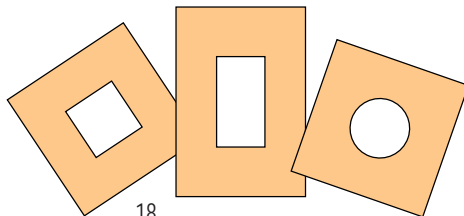

Simple templates for door and window apertures

4

CUTTER SELECTION

STRAIGHT CUTTERS

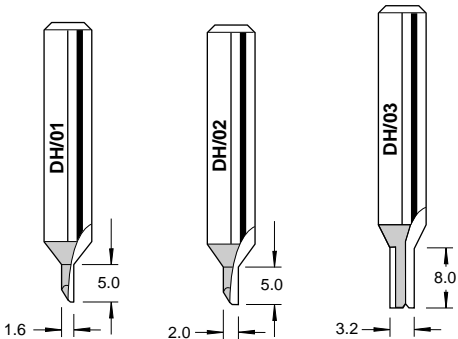

All dimensions in mm

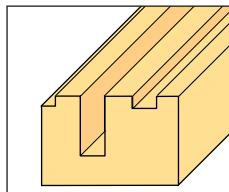

Rebates

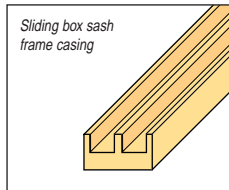
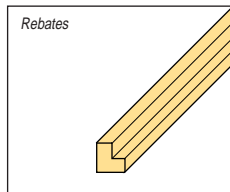

Sliding box sash frame casing

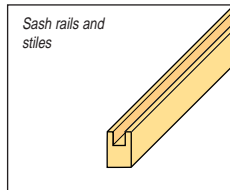

Sash rails and stiles

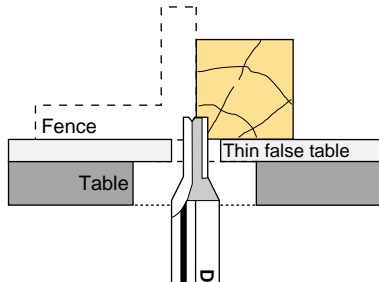
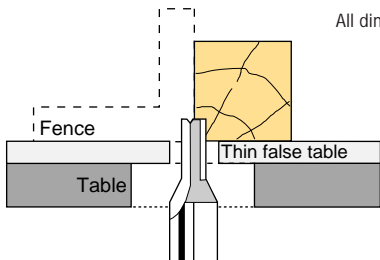

VICTORIAN BULL NOSE

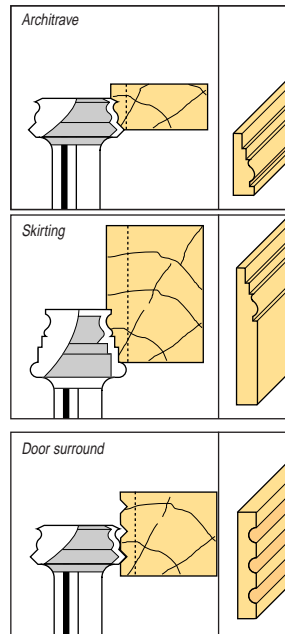
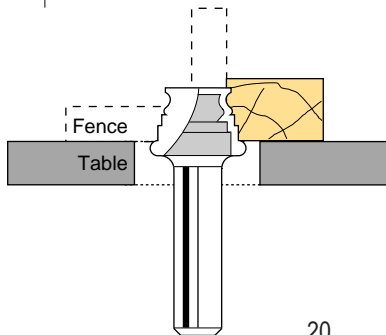
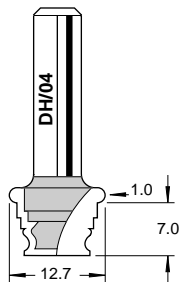

TORUS BEAD

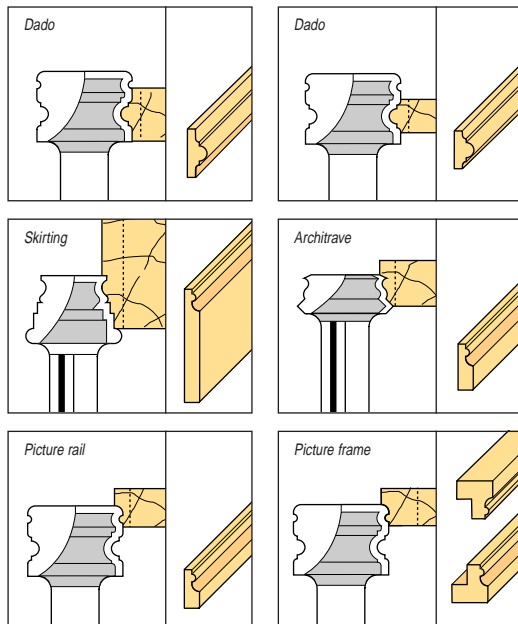
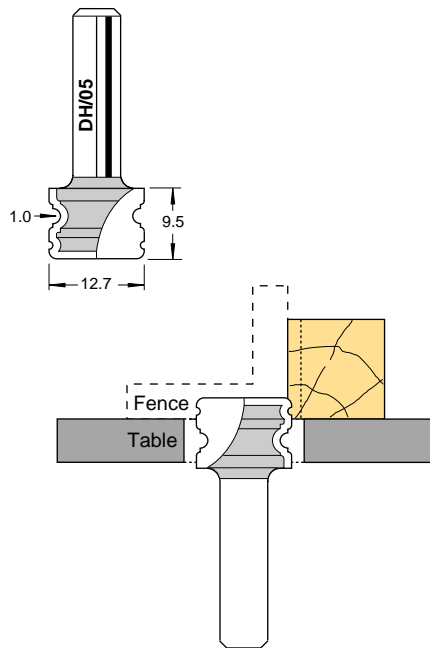

MULTI-MOULD

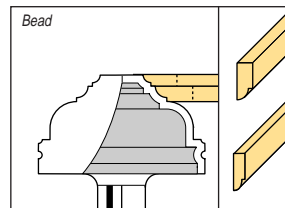
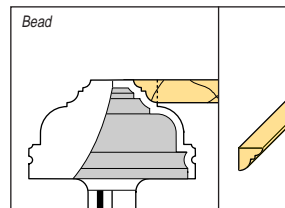
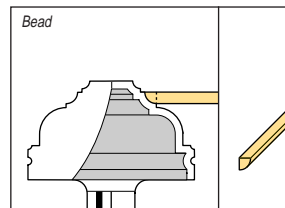
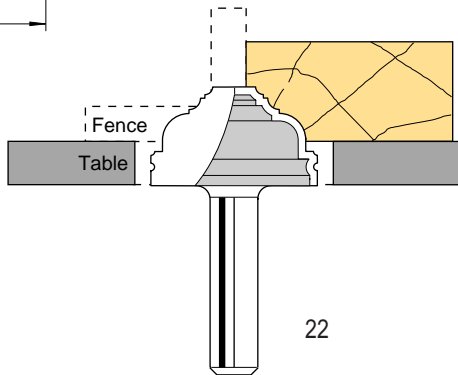
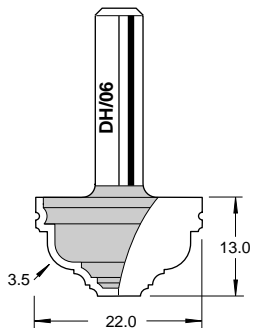

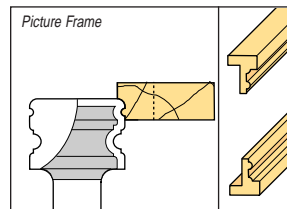
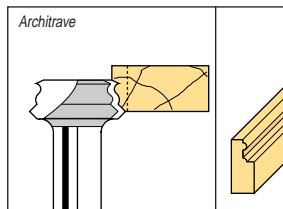
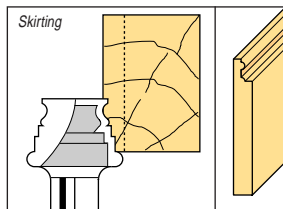
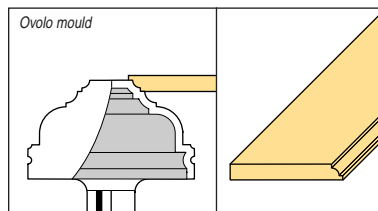
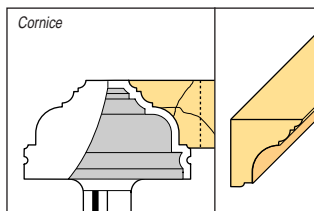
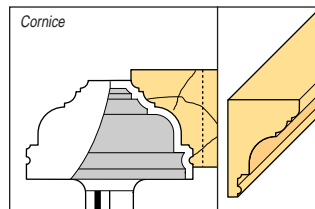
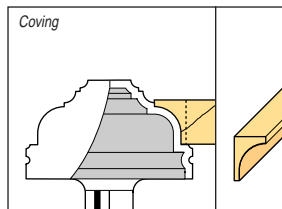
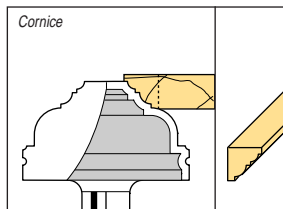

MODERN TORUS

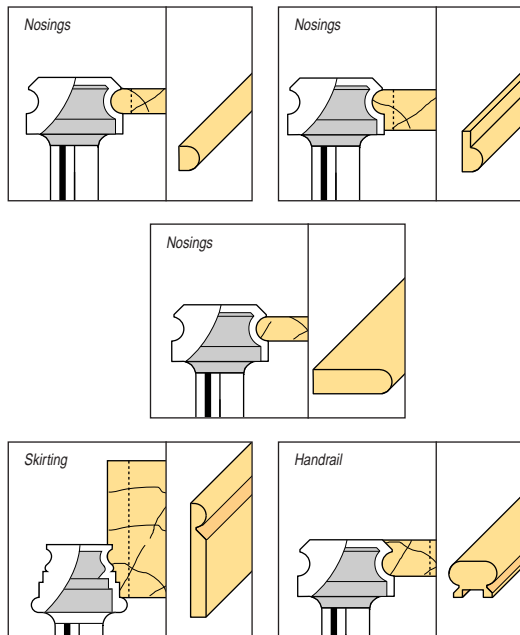
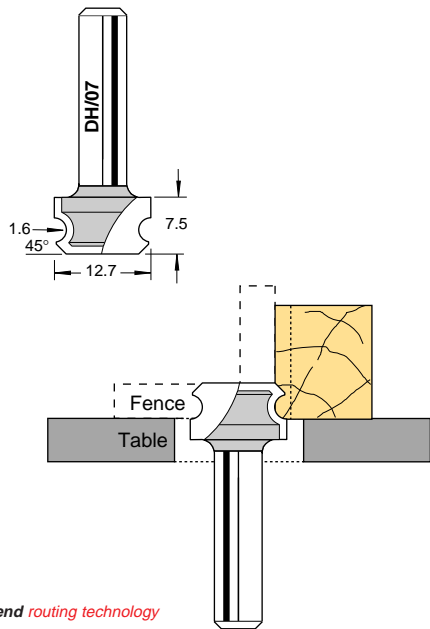

DOUBLE BEAD

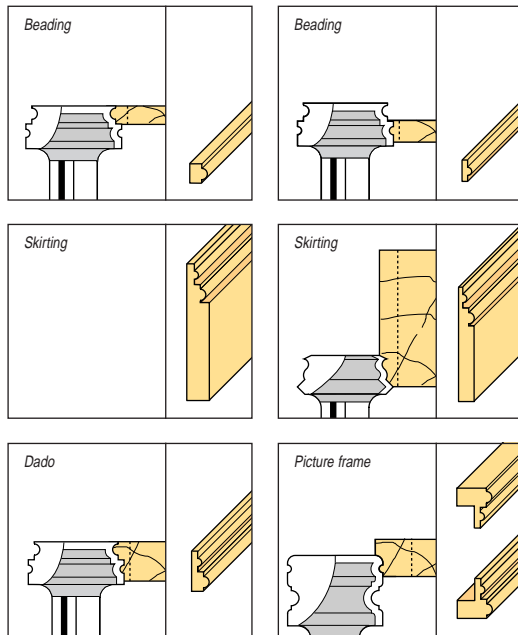
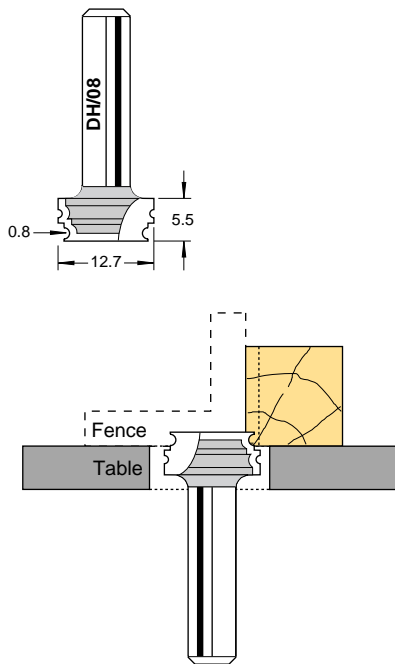

OGEE CLASSIC

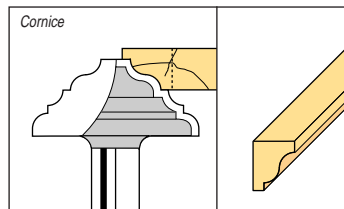
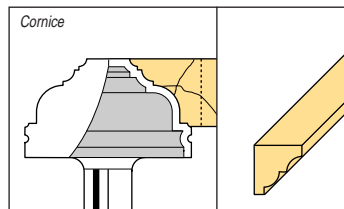
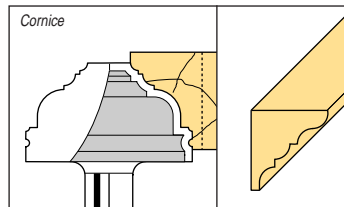
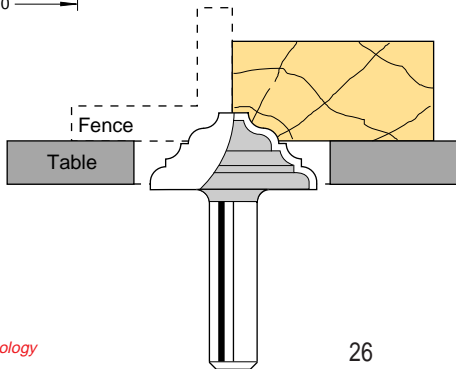
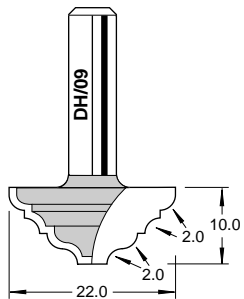

BEAD OGEE

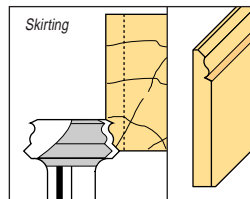
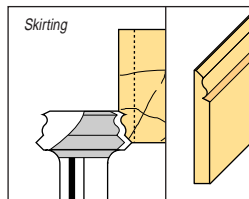
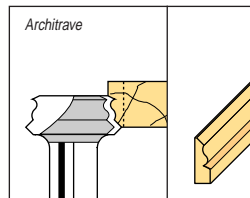
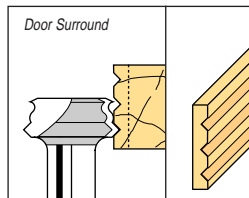
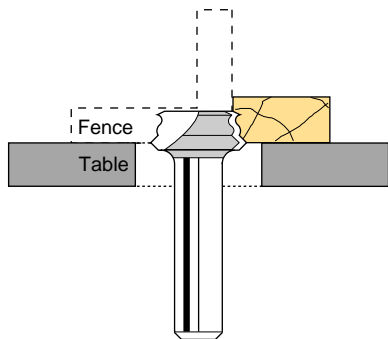
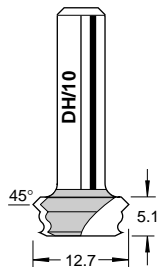

TRIPLE CLASSIC OVOLO

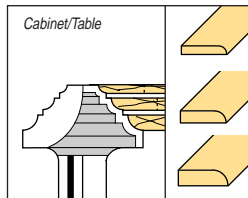
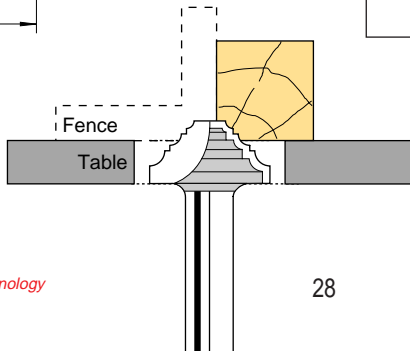
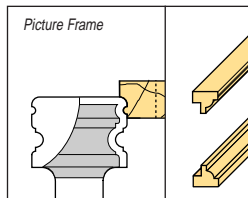
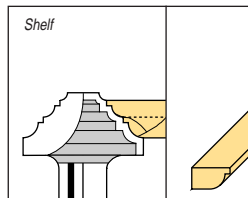
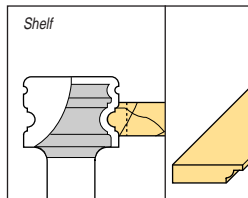
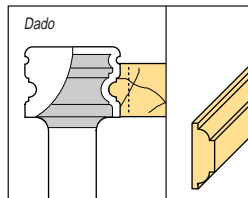
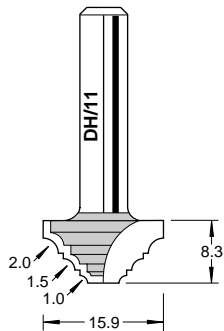

TRIPLE BEAD

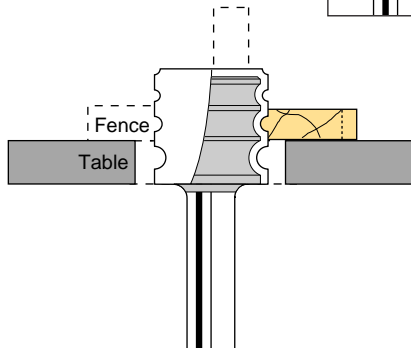
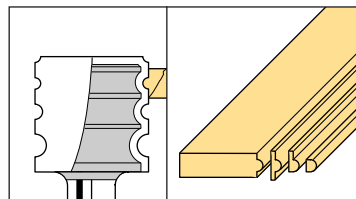
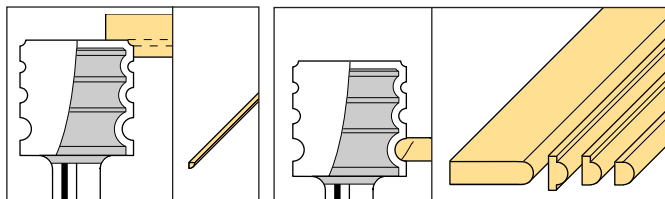
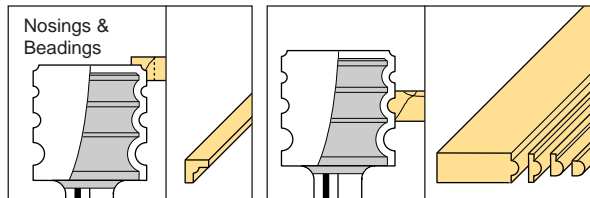
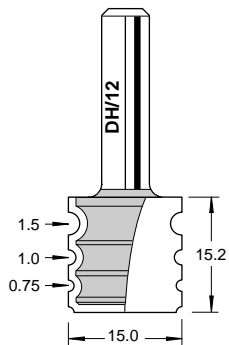

5 THE A-Z OF SAFETY

A **ALWAYS** use the router and other power tools in a safe manner and away from children.

B **BEWARE** of unsafe working practices and potential hazards when using a router.

C **CLOTHING** such as ties or loose or baggy garments, which may be accidentally caught and pulled into the cutter should not be worn or should be tied back when using a router.

D **DUST** presents a severe health risk if inhaled. Always wear a dust protector and/or use a vacuum extractor connected directly to the router.

E **EYE** protection must also be worn to protect the operator from ejected waste particles.

EAR protection should also be worn, when routing for long periods of time.

F **FEED** direction of the cutter into the workpiece or the workpiece into the cutter should be against the rotation of the cutter.

G **GUARDS** should always be used when using a router mounted in a table. Always ensure that your fingers cannot make contact with the cutter. Always use a push stick

together with hold down clamps when machining small timber sections when the router is mounted in a table.

H **HURRIED** setting up and routing can lead to accidents. Take your time to prepare yourself and the machine. Carry out safety checks before switching on.

I **INSPECT** the condition of the router cutter before use. Ensure that the cutter is held firmly in the collet, rotates freely and is well away from the work before the power is switched on.

J **JUDGE** the correct feed speed by listening to the tone of the router.

K **KEEP** router cutters sharp. Take care when handling them especially when removing them from the collet or from a storage block.

L **LISTENING** to the sound of the router will often indicate that the cut is being made too deep or that the cutter is blunt.

M **MANUALS** and other information supplied with the router or cutters should be read thoroughly to ensure you are familiar with the controls, functions, and operating procedures.

N NEVER leave the router running unattended. Wait until the router comes to a complete stop and switch off at the wall plug before making adjustments, changing the cutter or operating the spindle lock.

O OBSTRUCTIONS should be kept clear of the path of the router and the routing area. Do not clear swarf or other debris away from the cutting area with the machine still running.

P POWER to the router must always be switched off and the machine isolated from the supply before changing cutters or making adjustments. Make sure the power switch is 'Off', before plugging in, to avoid accidental starting.

Q QUESTIONS regarding the safe operation of your router can be answered, by Trend's Technical Department. The address and phone/fax numbers can be found at the end of this publication.

R ROUTERS must be allowed to reach their full running speed before commencing any routing operation. Do not switch the router on with the cutter touching the workpiece.

S SHORT-CUTS must not be taken to the detriment of safe working practice.

T TIDY work areas and benches help to prevent accidents. Always keep the floor around the work area clear of all obstacles. Store router on a shelf, in a cupboard or in a storage box, so chips and nails cannot fall into the air intake.

U UNDERSTANDING the current statutory woodworking regulations (such as the 'Supply of Machinery (Safety) regulations 1992' and 'The Provision and Use of Work Equipment Regulations 1992' and any amendments) is essential for all professional router users.

V NO-VOLT release switches should be fitted to all table mounted routers, both to isolate the router in an emergency and to prevent it switching back on when power is restored after a power failure or supply disconnection.

W WORKPIECES must always be securely and safely clamped to the work bench, in a vice or by some other means prior to commencing the routing operation. Do make sure that any clamps are not within the path of the router.

X EXAMINE the cutters and router collet before use. Equally check that any knobs or screws on the router are tight and have not vibrated loose.

Y YOUR safety when routing is more important than the router or its cutters.

Z ZERO accidents should be the first consideration when using routers and other power tools.

6

CUTTER & COLLET CARE



When honing your router cutters, apply light even pressure, and use an equal number of strokes on each cutting face.



Regular application of a dry lubricant spray will prevent resin build up.

It is essential to regularly maintain your cutters and collets in order to keep them in a safe and usable condition.

It will also help to maintain the life of your router by keeping the loads imposed upon it to a minimum.

Keeping your cutters sharp is a very simple operation requiring little skill and remembering a few basic rules.

Clean all resin deposits from the cutter with Resincleaner® solvent or by scraping with a piece of stiff plastic before applying a dry lubricant spray such as Trendicote.

Use a diamond sharpening stone to regularly hone your cutters, but only ever hone a router cutter on the flat face of the cutting edge.



Brass brushes should be used to remove deposits from the inside of the collet.



Rustbuster® is used to lubricate the pillars of the router & to prevent surface corrosion.



12 PIECE STARTER SET

An ideal first purchase with your router. A wooden box containing 12 essential cutters for your basic projects.

- Router cutters are tungsten carbide tipped.
- Suitable for grooving, profiling & moulding softwoods, hardwoods, MDF & plywood.
- Sets are available with 1/4" or 8mm shanks.

Order Ref: **SET/SS3**

SIX PIECE CUTTER SET

Developed from the highly successful SS3 set this economical set contains six popular TCT cutters supplied in a wooden box.

- Set comprises a 45° V-groove, a bearing guided ogee, two straights and two bearing guided rounding over cutters.
- Sets are available with 1/4" or 8mm shanks.

Order Ref: **SET/SS7**



CUTTER & COLLET CARE KIT

This kit contains all the essential accessories to maximise the life of your cutters, collets and router.

The kit comprises:

- A DMT mini-diamond sharpening stone and water bottle.
- Rustbuster® anti-corrosion agent spray.
- Trendicote® PTFE dry lubricant spray.
- Four sizes of brass brushes for cleaning collets.



Order Ref: **CCC/KIT**

4 PIECE CUTTER SET

A set of four TCT cutters aimed at those new to routing is now available.

- 10mm straight flute cutter.
- 60° V-groove cutter.
- 8mm bearing guided rounding over cutter.
- 12.7mm decorative panelling cutter.
- Sets are available with 1/4" or 8mm shanks.

Order Ref: **SET/SS6**



12 PIECE CUTTER SET FOR DOLLS HOUSES

This range of miniature cutters is designed to suit dolls house requirements at 1:12 scale and for all types of miniature or small scale work supplied in a wooden box.

- Router Cutters are TCT & 1:12 scale.
- Sets are available with 1/4" or 8mm shanks.

Order Ref: **SET/DH1**



TREND

BOOK/DH1



5 027654 105207

Available from your local **Trend** stockist.

trend[®]
routing technology

Trend Machinery & Cutting Tools Ltd

Watford England

Literature Hotline: 0800 4 TRENDS (0800 487363)

Technical: 01923 224681

Fax: 01923 236879

Email: mailserver@trendm.co.uk

WWW: <http://www.trendm.co.uk>